

Product Specifications

Customer	
Model	NTSM150-2 V500



Records of Revision			
Vision	Modifying	Old Description	New Description
v2208.1	Preliminary Specifications		
v2208.2	New trademark released		

Features

- ★ 15 inch Industrial Grade Panel, 1024x768 Resolution
- ★ IAV Wide Viewing Angle Technology , 176°/176°
- ★ Operating Temperature Range -30~80°C
- ★ Metal Cabinet with Diverse Combine Options
- ★ Made in Taiwan, 3 Years Warranty, Designed for Harsh Environments
- ★ VGA/HDMI/DP Video Input
- ★ Resistive Touch Options, Supports NEXTECH Dedicated Stylus
- ★ Optional Software Remote Control by RS232 or DDC/CI
- ★ Optional High Brightness 1500nits, for Outdoor Environment
- ★ Optional Auto Dimming Function (with Light Sensor)
- ★ Optional AG Coating/Antibacterial/Privacy Filter Surface Treatment



Desktop Stand



Wall Mounting



Open-frame Bracket



Panel Mount

Display Specifications

Model Name	NTSM150XX232-XXXXXX-500*	Display Mode	IVA Mode, Normally Black
Screen Diagonal	15.0 inch	Response Time	18 msec.
Display Area	304.1x228.1 mm	Backlight Unit	LED (white LED)
Resolution	1024x768	Viewing Angle (L/R, U/D)	176°/176°
Contrast Ratio	2500:1	Backlight Lifetime	>70,000 Hours
Display Ratio	4:3	Operating Temp.	-30~80°C
Support Colors	16.7M Colors	Storage Temp.	-40~85°C
Pixel Pitch	297x297 um		

* X = A~Z, 0~9 (Depends on options)

Display Options

Brightness			
	Brightness	Environment	Model Name
Standard	500nits	General (Indoor)	NTSM150NX232-XXXXXX-500
Option 1	1000nits	Outdoor Environment	NTSM150AX232-XXXXXF-500
Option 2	1500nits	Sunlight Readable	NTSM150FX232-XXXXXF-500

Accessories

Item	Description	Quantity
HDMI Cable	Male to Male, 1.8 Meter	1
AC-DC Adapter	12V with CE/FCC/CCC/UL/RoHS/PSE/JET Certification	1
Power Cord	*Country Specific	1
USB Cable	A type, Male to Male, 1.8 Meter *(only for touch monitor)	1

Touch Options

Resistive Touch			
Model Name	NTSM150X ⁵ 232-XXXXBX-500		
Touch Technology	Resistive Touch	Transparency	80%±5%
Allowed Touch Points	1 point	Surface Treatment	Anti-glare<15%
Interface	USB/RS232	Hardness	≥3H
Precision	98.50%		

Non-Touch	
Model Name	NTSM150X ⁰ 232-XXXX0X-500

Passive Stylus Pen (Option)	
Technology	Passive High Sensitive Knitted Wire Mesh Fiber Tip
Size of tip	6mm
Magnetic Attachment	Yes

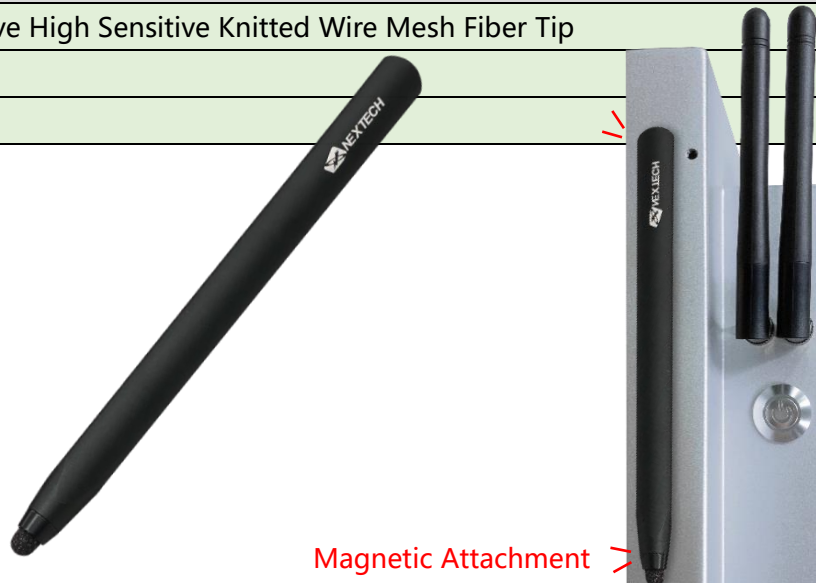

General Options

Surface Treatment		
	Description	Model Name
Standard	(none)	NTSM150XX232-00XXXX-500
Option 1	Anti-Glare Coating	NTSM150XX232-GGXXXX-500
Option 2	Antibacterial (AB Film)	NTSM150XX232-ABXXXX-500
Option 3	Anti-Spy (AS Film)	NTSM150XX232-SFXXXX-500

Color of Cabinet		
	Description	Model Name
Standard	Black	NTSM150XX2232-XXBXXX-500
Option 1	White	NTSM150XX232-XXWXXX-500
Option 2	Silver	NTSM150XX232-XXSXXX-500
Options	Other Colors	NTSM150XX232-XXXXXX-500

* X = A~Z, 0~9 (Depends on Color)

Material of Cabinet		
	Description	Model Name
Standard	SECC	NTSM150XX232-XXXSXX-500
Option 1	Stainless Steel	NTSM150XX232-XXXLXX-500
Option 2	Aluminum	NTSM150XX232-XXXAXX-500

Touch Interface		
	Description	Model Name
Standard	USB+RS232	NTSM150X52XX-XXXXBX-500
Option 1	Non-Touch	NTSM150X02XX-XXXX0X-500

Cooling Fan		
	Description	Model Name
Standard	Fanless	NTSM150XX232-XXXXX0-500
Option	7 Blades/4000r.p.m/28.3dB	NTSM150XX232-XXXXXF-500

Input /Output System

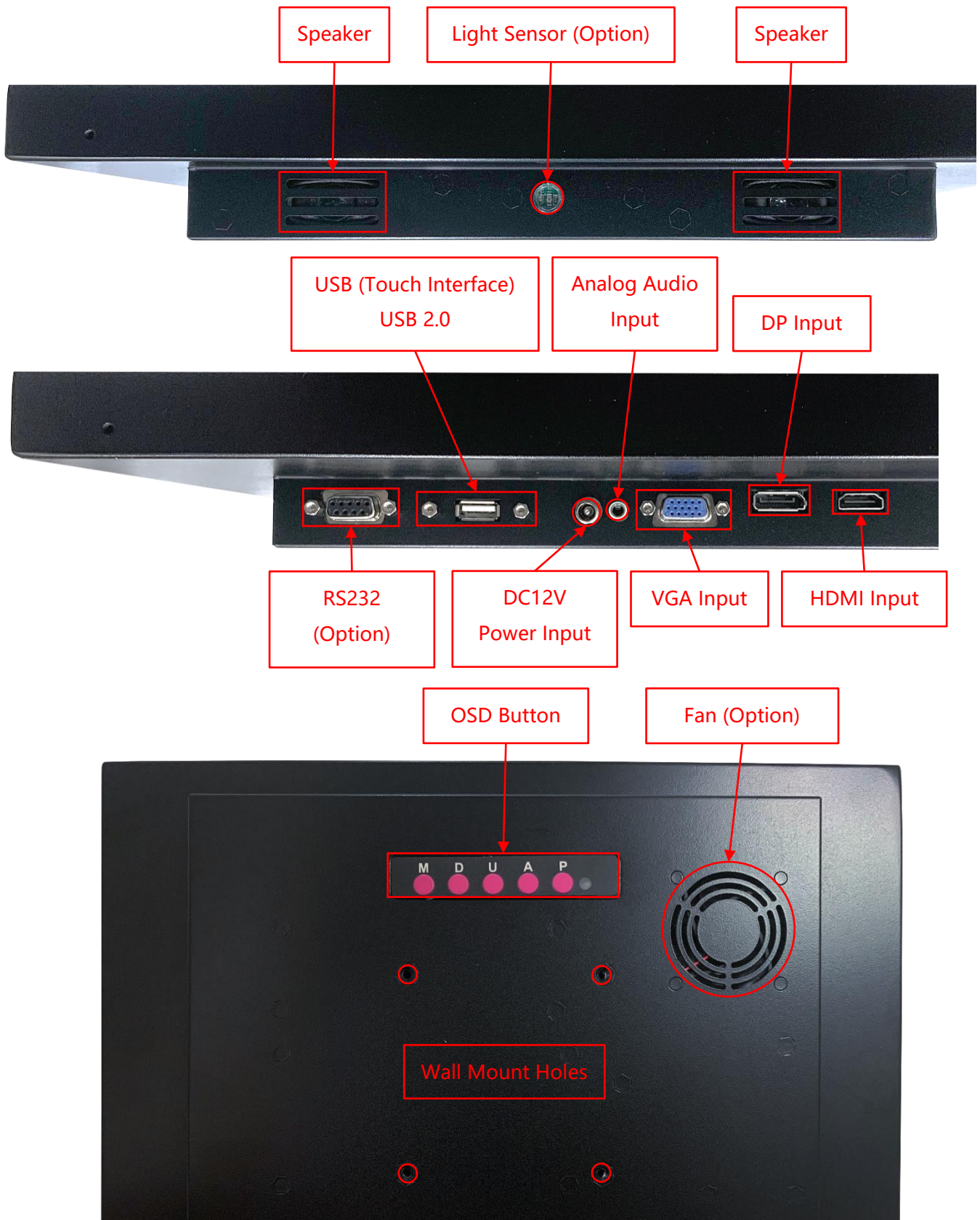

Other Options

OSD Control		
	Item	Description
Standard	Button	Rear Physical Button
Option 1	Software Remote Control	Software Remote Control by RS232/Serial Port
Option 2	Auto Dimming	Auto Brightness Adjusting by Light Sensor

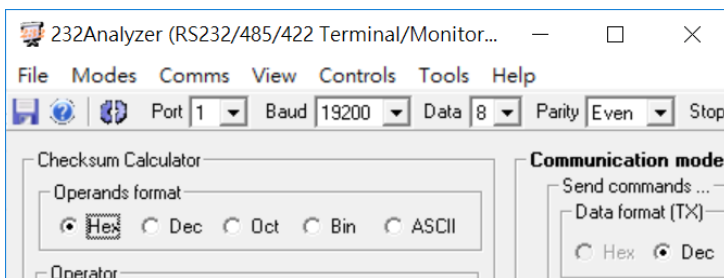

* Software Remote Control

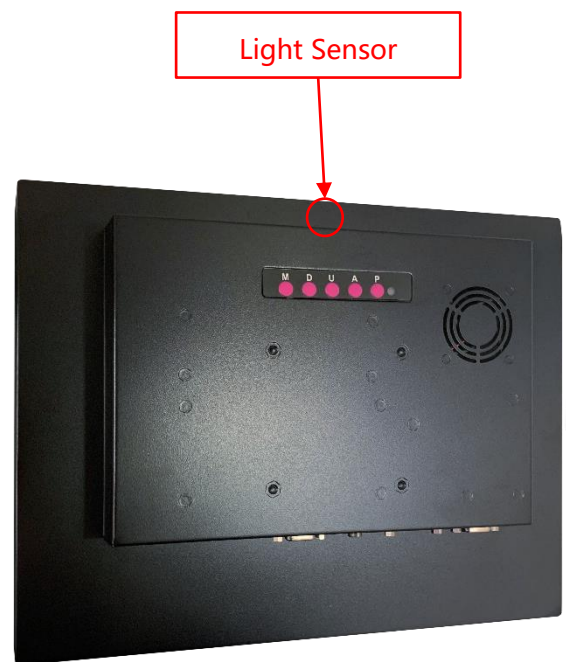

Supported OS

Windows	Win7, Win8, Win10, Win11 ↑
Linux	Kernel 2.6.24 ↑
Android	3.0 ↑
Mac	10.5.x ↑ (Intel CPU)

Open-frame Brackets (Option)

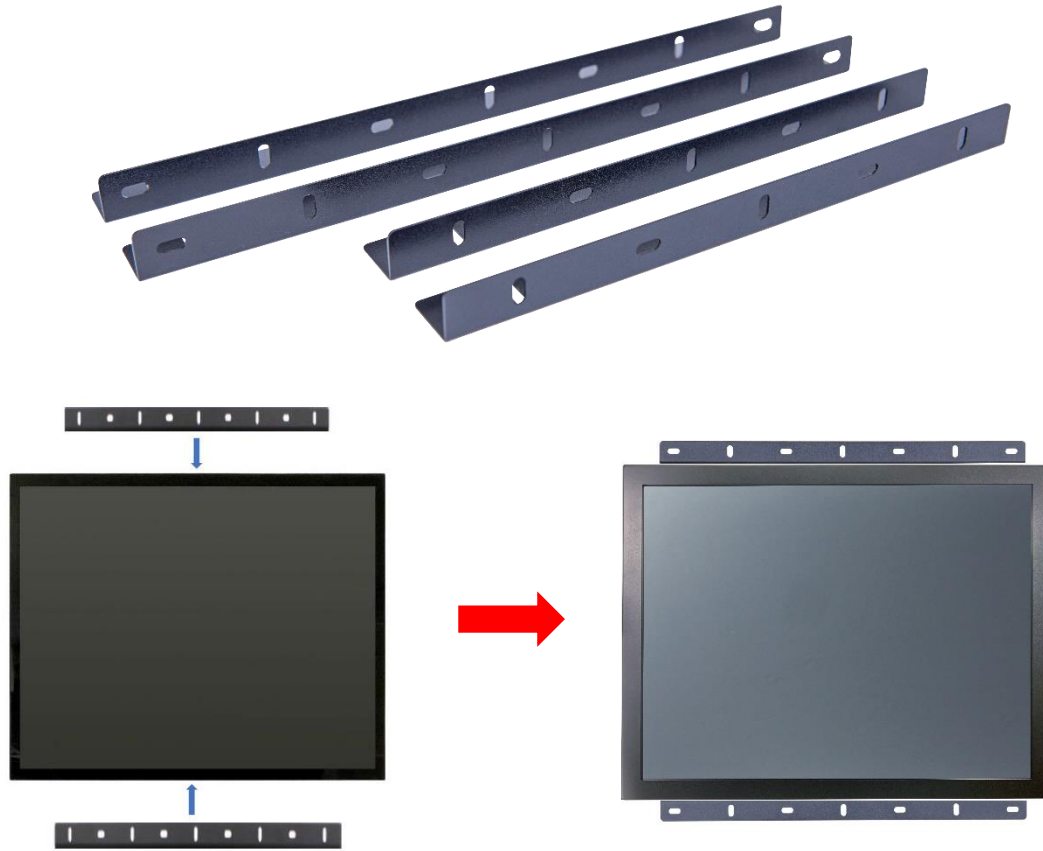

Dimension for Installing with Open-frame Brackets

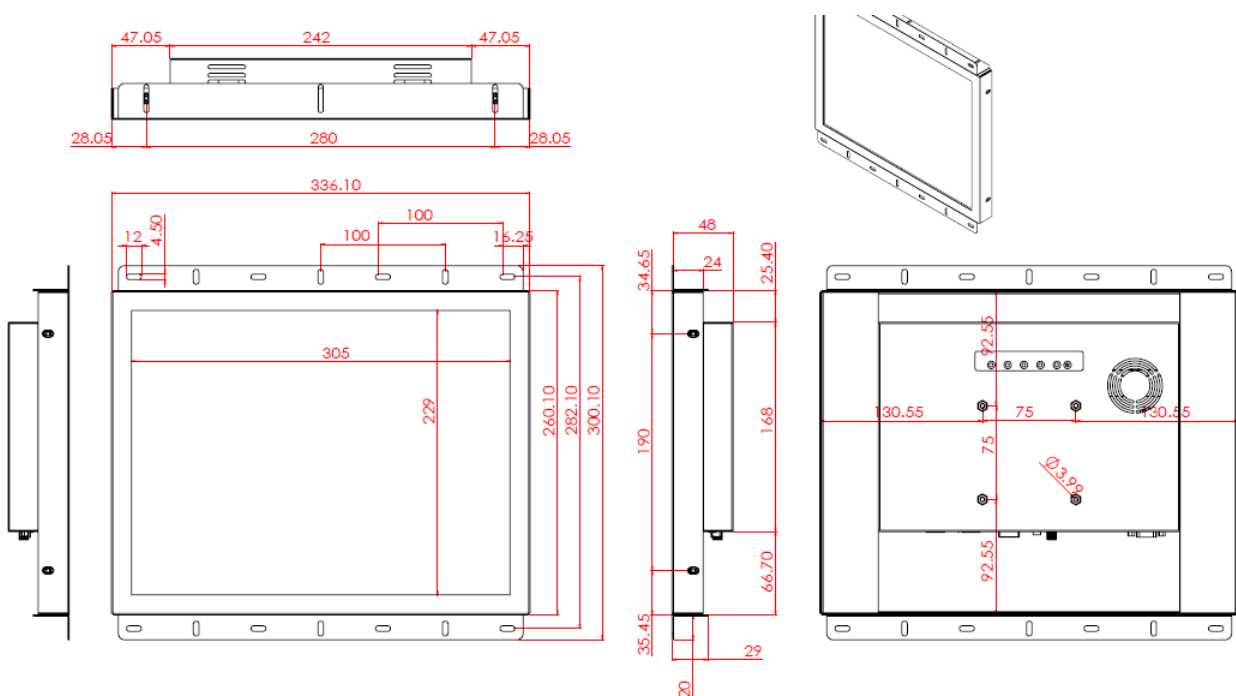

Panel Mount Kits (Option)



Dimension for Installing with Panel Mount Kits

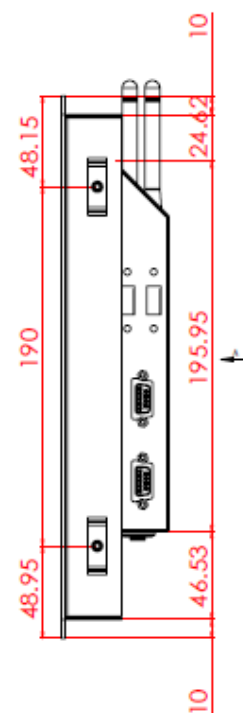
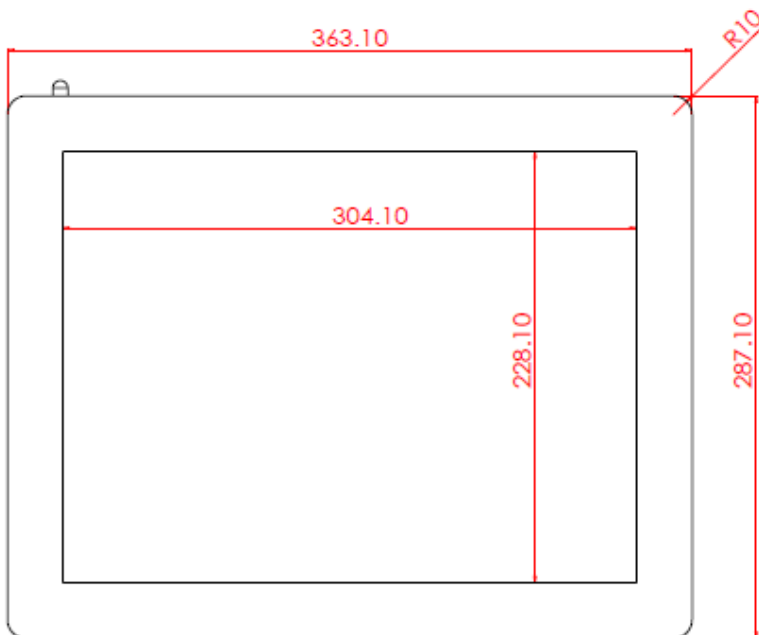
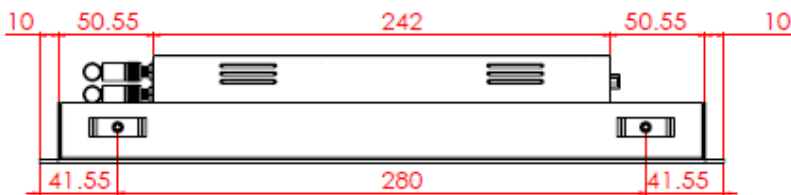

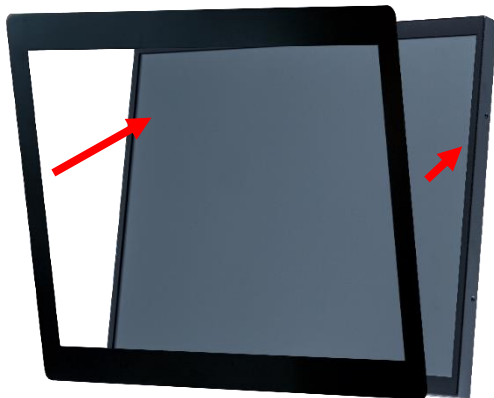

Step 1: Assemble the front module with the screen body. (This step is pre-assembled at the factory.)

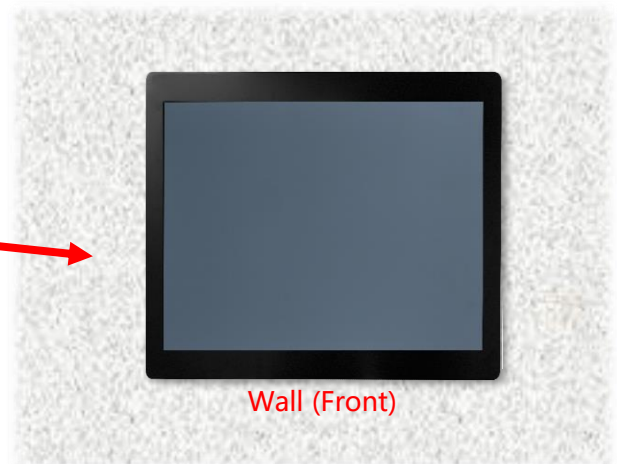
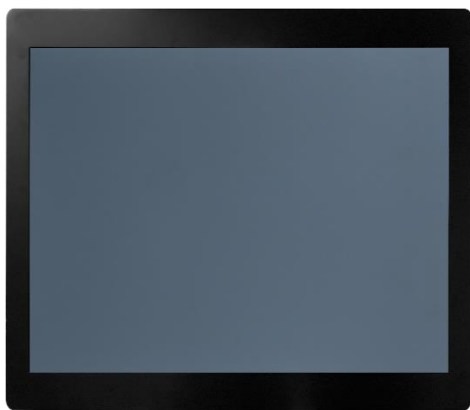
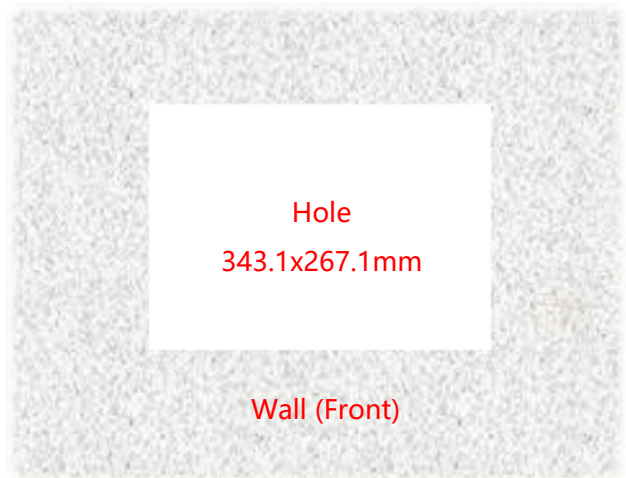

Step 2: Insert the screen from the front into the pre-cut opening.

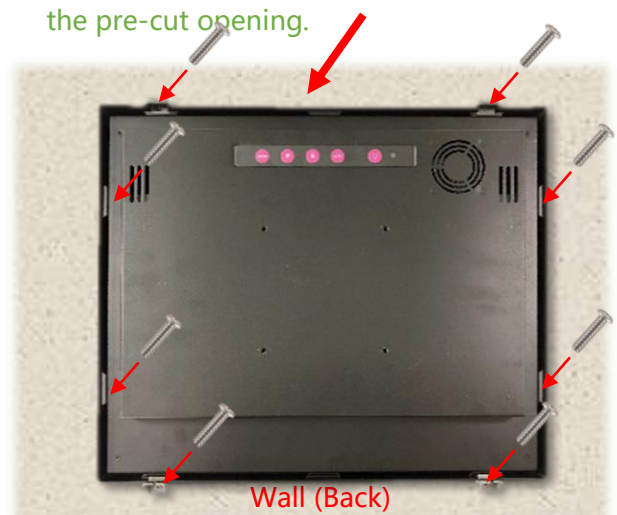

Step 3: Attach the clips from the back and secure with screws. (Up to 10 clips can be installed as needed or per positional limitations.)

Desktop Stand (Option)

Item	L Stand	Part No.	DST-0B004/DST-1B004
Mounting Pattern	100x100 / 75x75 mm	Dimension (WxHxD)	194x194x222 mm
Material	SECC	Net Weight	1.4 KG
Tilt (Hinge)	105°	Support Max. Weight	15 KG

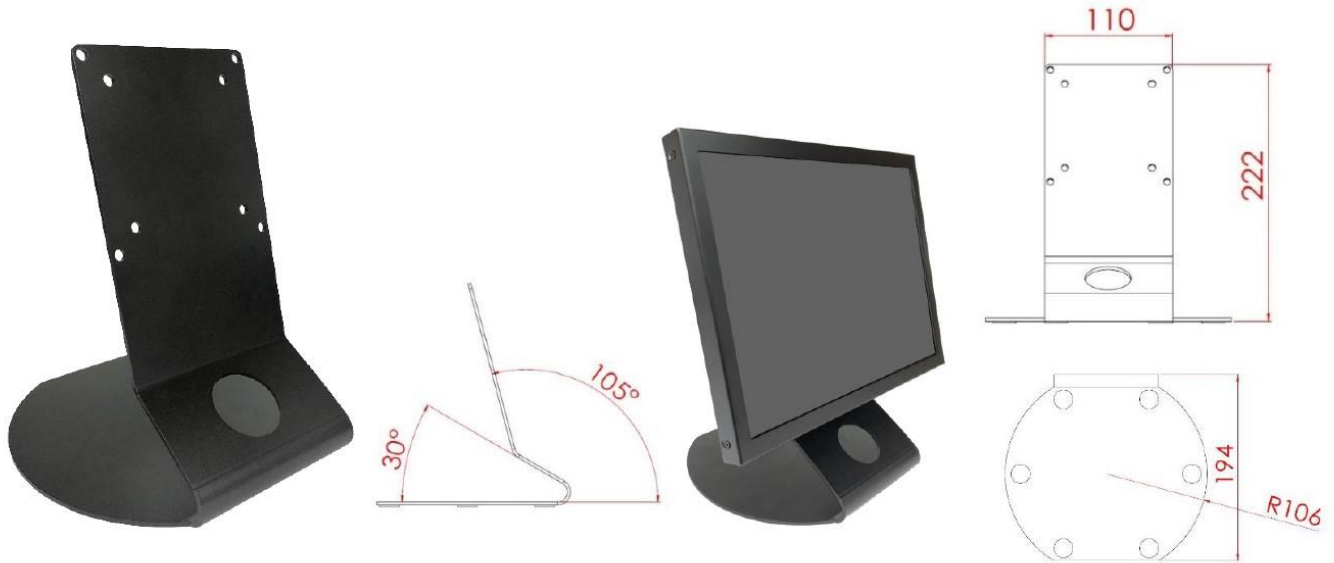

Item	B Stand	Part No.	DST-0B002/DST-1B002
Mounting Pattern	100x100 / 75x75 mm	Dimension (WxHxD)	203x275x227 mm
Material	Steel/Plastic/Aluminum	Net Weight	1.8 KG
Tilt (Hinge)	-2° ~ +180°	Support Max. Weight	15 KG



Wall Mount Bracket (Option)

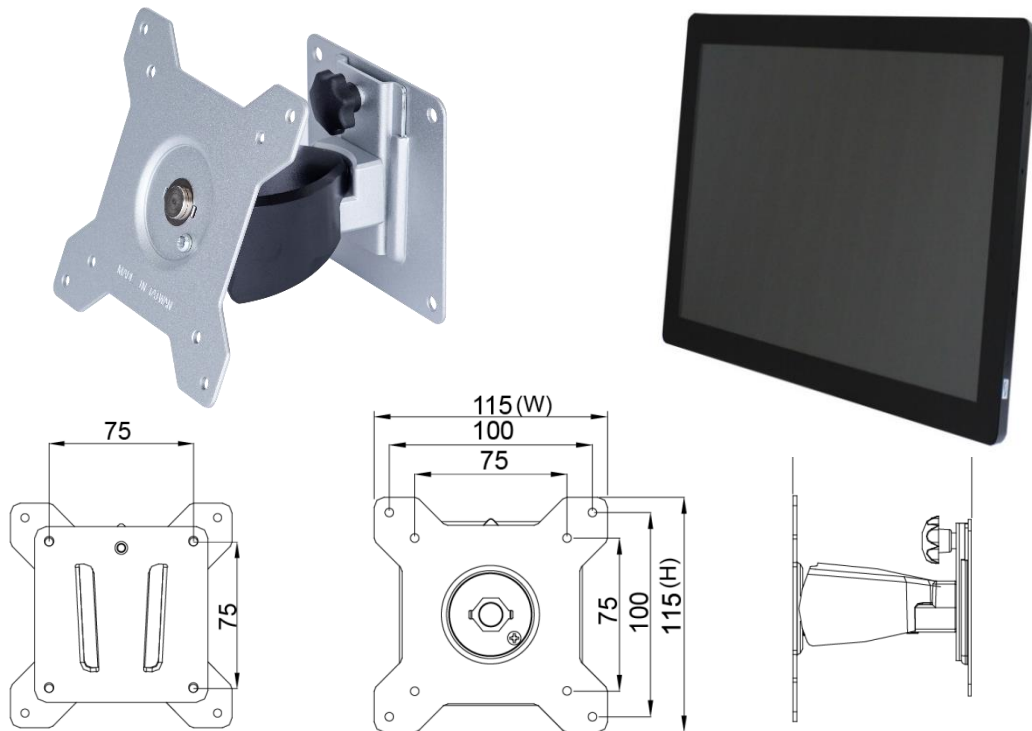

Packing Information

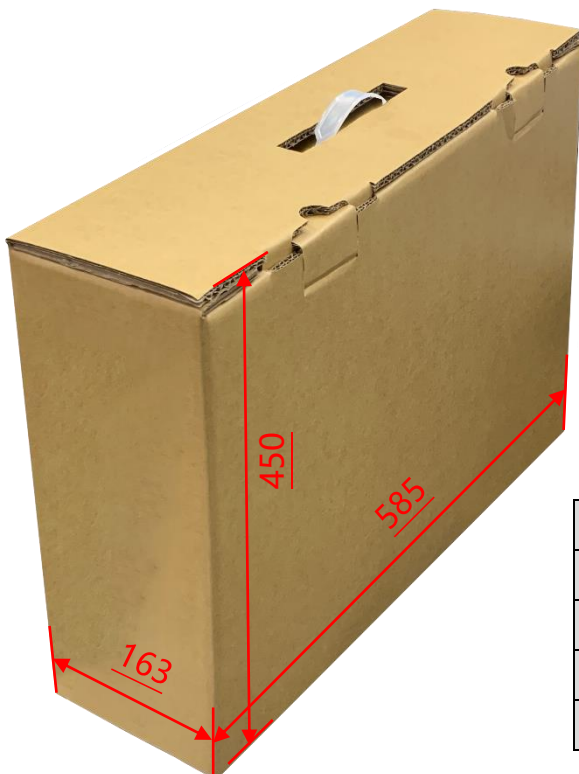

Unit Carton Size	585x163x450 mm
Unit N. Weight	≤3.1 KG
Unit G. Weight	≤5.0 KG
Units per Pallet	36 units
Pallet Size	120x100x147 CM

Physical Specifications

Dimension (Max)	336x260x48(±2)mm	Net Weight	3.1 KG
VESA Mounting	75x75 mm	Gross Weight	5.0 KG

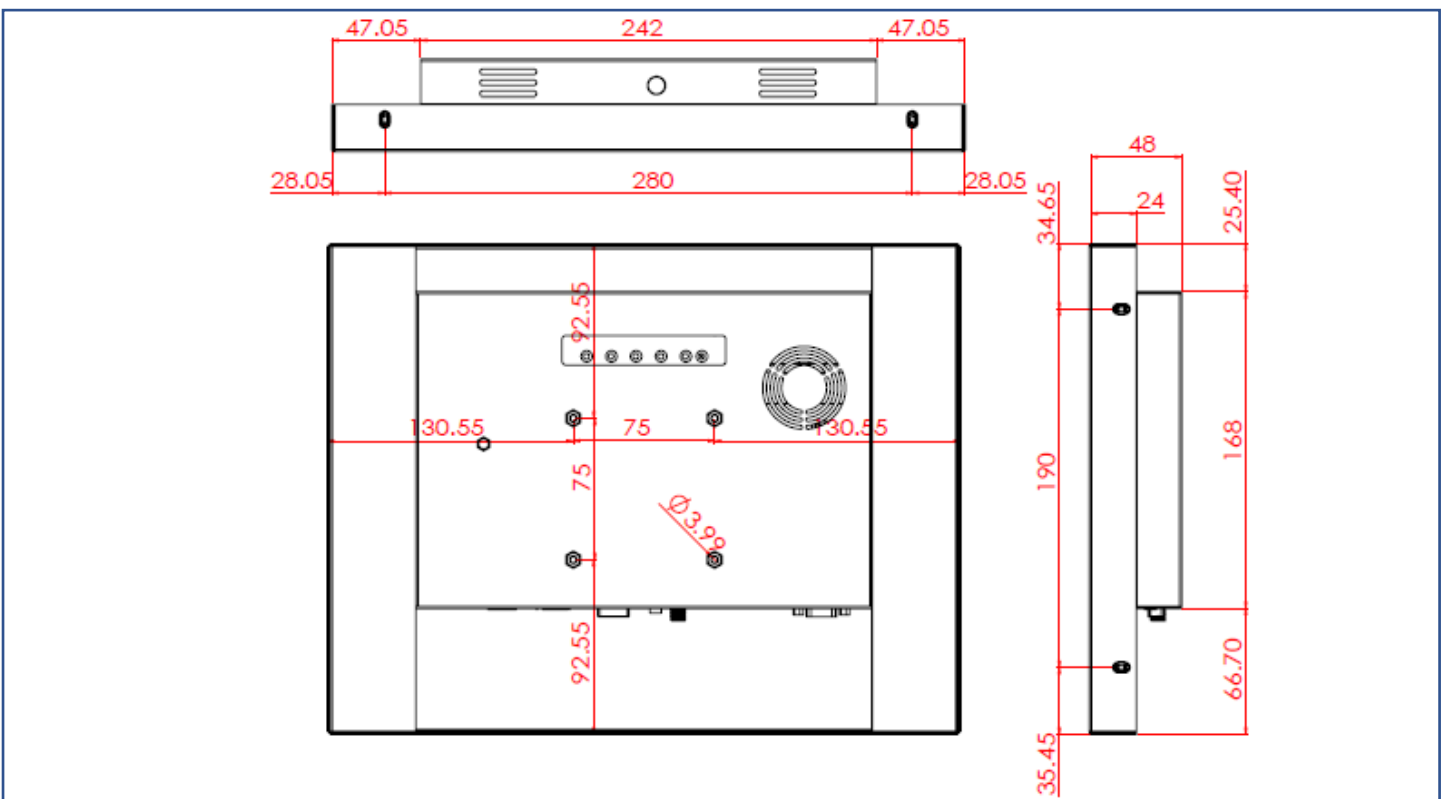
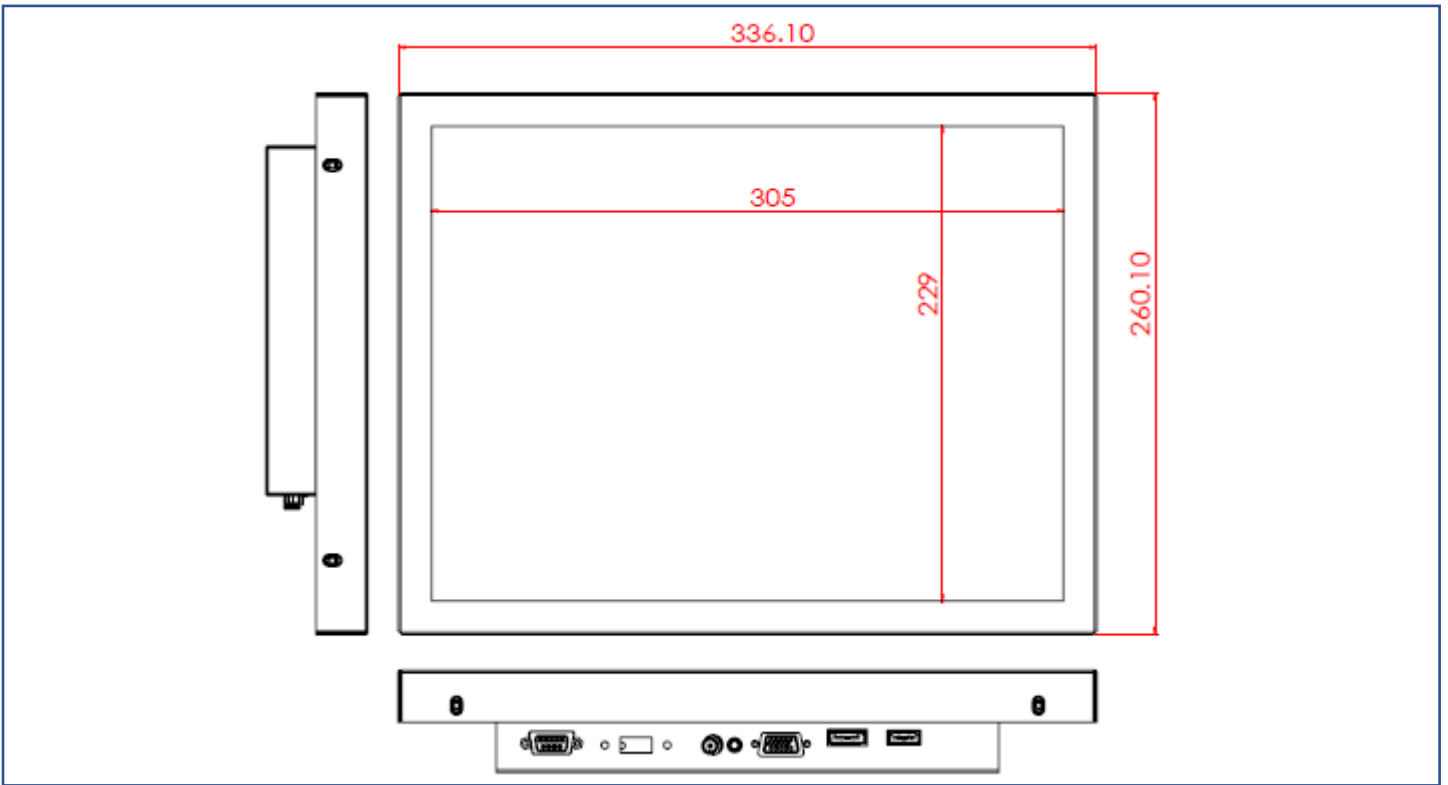

Cosmetic Inspection Standard

Display Area Allowance			
Defect description	Defective Specifications	Allowance	Remarks
Dot Defect (including dark dot, particles, bubbles, pits, dust, foreign matter)	$D \leq 0.2\text{mm}$	Ignored	D=Diameter
	$0.2 < D \leq 0.7\text{mm}$	$N \leq 5$	N=Quantity
	$0.7 < D \leq 1\text{mm}$	$N \leq 3$	
	$D > 1\text{mm}$	$N \leq 0$	
Linear Defect (including scratches, fluff, particles)	$W \leq 0.15\text{mm}$	Ignored	W=Width
	$0.15 < W \leq 0.5\text{mm}, L \leq 15\text{mm}$	$N \leq 2$	L=Length
	$W > 0.5\text{mm}$ or $L > 15\text{mm}$	NG	

* Visual inspection distance: 60cm, 90 degree (same for front/side/back)

Front Appearance Allowance (Including Coating)			
Defect description	Defective Specifications	Allowance	Remarks
Dot Defect (including particles, bubbles, pits...etc.)	$D \leq 0.7\text{mm}$	Ignored	D=Diameter
	$0.7 < D \leq 1.5\text{mm}$	$N \leq 3$	N=Quantity
	$D > 1.5\text{mm}$	$N \leq 0$	
Linear Defect (including scratches, fluff, particles)	$W \leq 0.2\text{mm}, L \leq 15\text{mm}$	Ignored	W=Width, L=Length
	$0.2 < W \leq 0.7\text{mm}, L \leq 15\text{mm}$	$N \leq 1$	
	$W > 0.7\text{mm}$ or $L > 15\text{mm}$	NG	

Side / Back Appearance Allowance (Including Coating)			
Defect description	Defective Specifications	Allowance	Remarks
Dot Defect (including particles, bubbles, pits...etc.)	$D \leq 1.5\text{mm}$	Ignored	D=Diameter
	$1.5 < D \leq 3\text{mm}$	$N \leq 8$	N=Quantity
	$D > 3\text{mm}$	$N \leq 2$	
Linear Defect (including scratches, fluff, particles)	$W \leq 0.8\text{mm}, L \leq 15\text{mm}$	Ignored	W=Width, L=Length
	$0.8 < W \leq 1.5\text{mm}, L \leq 15\text{mm}$	$N \leq 5$	
	$W > 1.5\text{mm}$ or $L > 15\text{mm}$	NG	

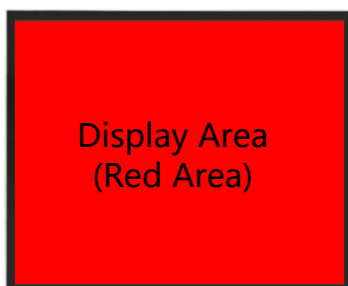

Display Area
(Red Area)



Front Appearance (Red Area)



Back Appearance