



# Product Specifications

<b>Customer</b>	
<b>Model</b>	<b>NTSP150-2 V500</b>



Records of Revision			
Vision	Modifying	Old Description	New Description
v2208.2	Preliminary Specifications		

### Features

- ★ 15 inch Industrial Grade Panel, 1024x768 Resolution
- ★ IVA Wide Viewing Angle Technology , 176°/176°
- ★ Operating Temperature Range -30~80°C
- ★ Narrow Bezel, True Flat Projected Capacitive Touch Screen
- ★ 7H Hardness Tempered Cover Glass
- ★ 10 points Multi-touch, Supports Active Stylus
- ★ Metal Cabinet with Diverse Combine Options
- ★ Made in Taiwan, 3 Years Warranty, Designed for Harsh Environments
- ★ VGA/HDMI/DP Video Input
- ★ Optional Software Remote Control by RS232
- ★ Optional High Brightness 1500nits, for Outdoor Environment
- ★ Optional Auto Dimming Function (with Light Sensor)
- ★ Optional AG Coating/Antibacterial/Privacy Filter Surface Treatment



Desktop Stand



Wall Mounting



Open-frame Bracket



Panel Mount



## Display Specifications

Model Name	NTSP150 <u>XX</u> 232- <u>XXXXXX</u> -500*	Display Mode	IVA Mode, Normally Black
Screen Diagonal	15.0 inch	Response Time	18 msec.
Display Area	304.1x228.1 mm	Backlight Unit	LED (white LED)
Resolution	1024x768	Viewing Angle (L/R, U/D)	176°/176°
Contrast Ratio	2500:1	Backlight Lifetime	>70,000 Hours
Display Ratio	4:3	Operating Temp.	-30~80°C
Support Colors	16.7M Colors	Storage Temp.	-40~85°C
Pixel Pitch	297x297 um	Surface Treatment	Anti-glare, Hardness 3H

\* X = A~Z, 0~9 (Depends on options)

## Display Options

Brightness			
	Brightness	Environment	Model Name
Standard	500nits	General (Indoor)	NTSP150 <u>N</u> X232- <u>XXXXXX</u> -500
Option 1	1000nits	Outdoor Environment	NTSP150 <u>A</u> X232- <u>XXXXXF</u> -500
Option 2	1500nits	Sunlight Readable	NTSP150 <u>F</u> X232- <u>XXXXXF</u> -500

## Accessories

Item	Description	Quantity
HDMI Cable	Male to Male, 1.8 Meter	1
AC-DC Adapter	12V with CE/FCC/CCC/UL/RoHS/PSE/JET Certification	1
Power Cord	*Country Specific	1
USB Cable	A type, Male to Male, 1.8 Meter *(only for touch monitor)	1

## Touch Options

Projected Capacitive			
Model Name	NTSP150X <u>P</u> 232- <u>XXXXXX</u> -500		
Touch Technology	Projected Capacitive	Transparency	≥87%
Allowed Touch Points	10 points	Accuracy	99.00%
Transparency	USB/RS232 (Option)	Thickness of Cover Lens	1.8±0.2mm
Accuracy	IK07	Hardness of Cover Lens	7H

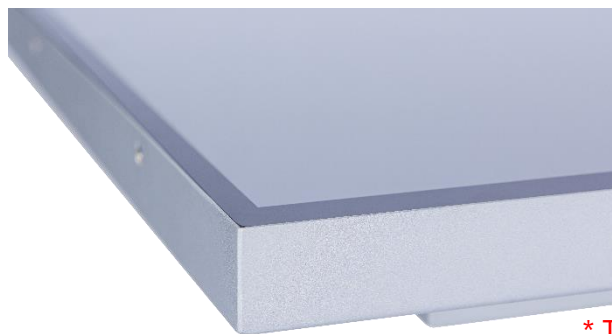

\* True Flat, 1mm Bezel

Non-Touch	
Model Name	NTSP150X <u>0</u> 232- <u>XXXX0X</u> -500

Active Stylus (Option)	
Technology	Active Capacitive Coupled
Working Frequencies	90~250 KHZ
Pressure Level	256~1024 Levels
Side Buttons	2 Side Buttons (Eraser, Barrel)
Active Tip Force	5~25g
Max. Tip Force	400g

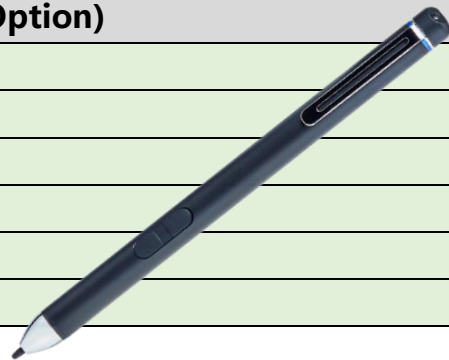



## General Options

Surface Film Options		
	Description	Model Name
<b>Standard</b>	<b>(none)</b>	<b>NTSP150XX232-00XXXX-500</b>
Option 1	Anti-Glare Coating	NTSP150XX232-GGXXXX-500
Option 2	Antibacterial (AB Film)	NTSP150XX232-ABXXXX-500
Option 3	Anti-Spy (AS Film)	NTSP150XX232-SFXXXX-500

Color of Cabinet		
	Description	Model Name
<b>Standard</b>	<b>Black</b>	<b>NTSP150XX232-XXBXXX-500</b>
Option 1	White	NTSP150XX232-XXWXXX-500
Option 2	Silver	NTSP150XX232-XXSXXX-500
Options	Other Colors	NTSP150XX232-XXXXXX-500

\* X = A~Z, 0~9 (Depends on Color)

Material of Cabinet		
	Description	Model Name
<b>Standard</b>	<b>SECC</b>	<b>NTSP150XX232-XXXSXX-500</b>
Option 1	Stainless Steel	NTSP150XX232-XXXLXX-500
Option 2	Aluminum	NTSP150XX232-XXXAXX-500

Touch Interface		
	Description	Model Name
<b>Standard</b>	<b>USB</b>	<b>NTSP150XP232-XXXXUX-500</b>
Option 1	RS232	NTSP150XP232-XXXXRX-500
Option 2	Non-Touch	NTSP150X0232-XXXX0X-500

Cooling Fan		
	Description	Model Name
<b>Standard</b>	<b>Fanless</b>	<b>NTSP150XX232-XXXXX0-500</b>
Option	7 Blades/4000r.p.m/28.3dB	NTSP150XX232-XXXXXF-500

## Input /Output System

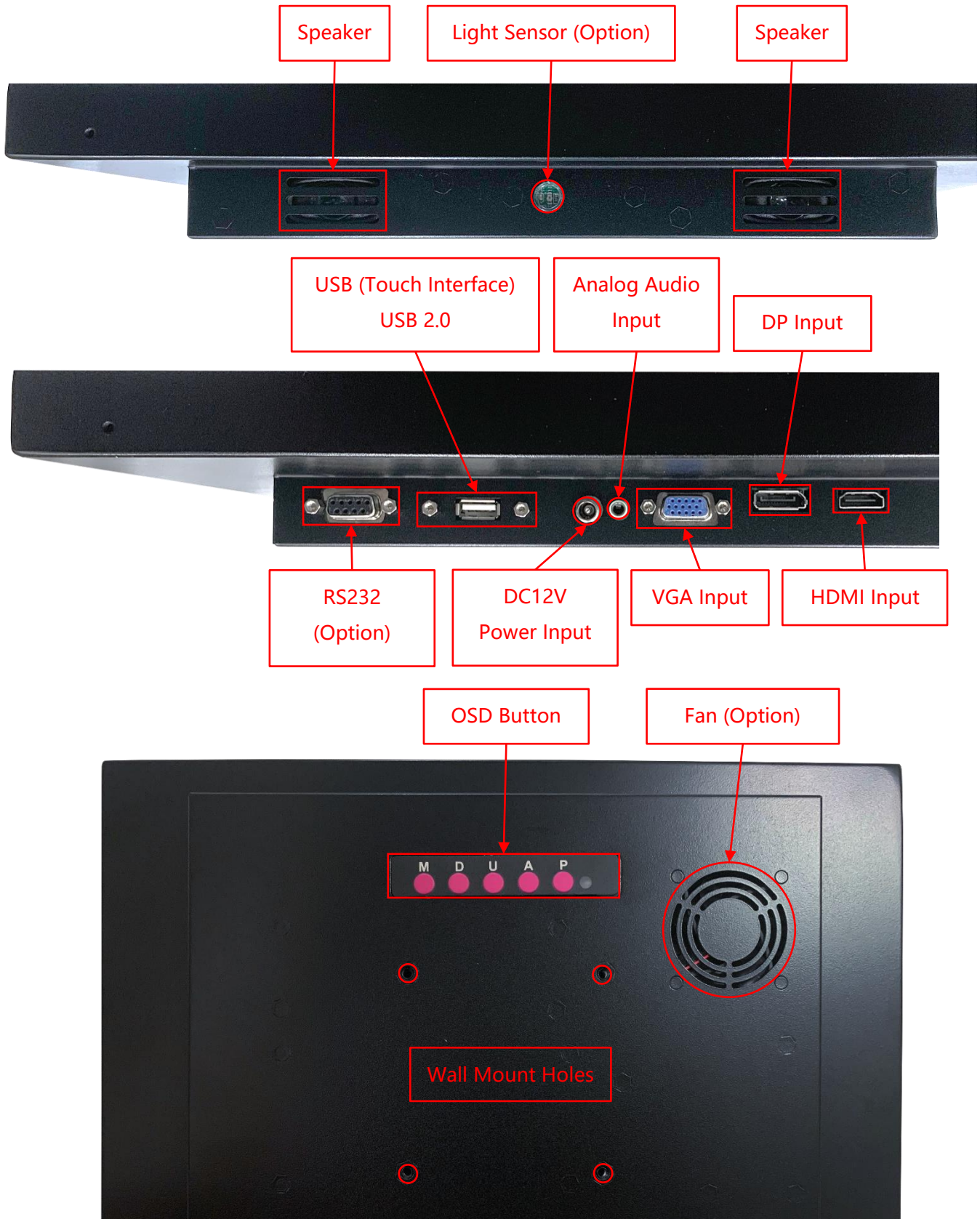

## Other Options

OSD Control		
	Item	Description
<b>Standard</b>	<b>Button</b>	<b>Rear Physical Button</b>
Option 1	Software Remote Control	Software Remote Control by RS232/Serial Port
Option 2	Auto Dimming	Auto Brightness Adjusting by Light Sensor

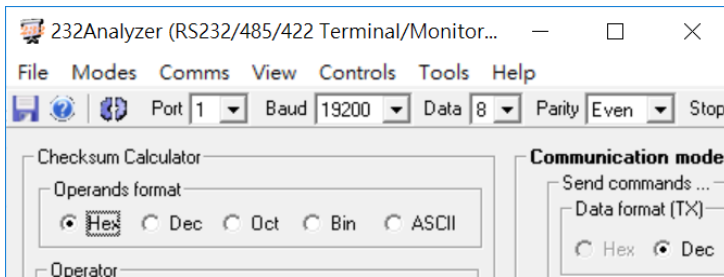

\* Software Remote Control



## Supported OS

Windows	Win7, Win8, Win10, Win11 ↑
Linux	Kernel 2.6.24 ↑
Android	3.0 ↑
Mac	10.5.x ↑ (Intel CPU)

## Front Cover (Option)

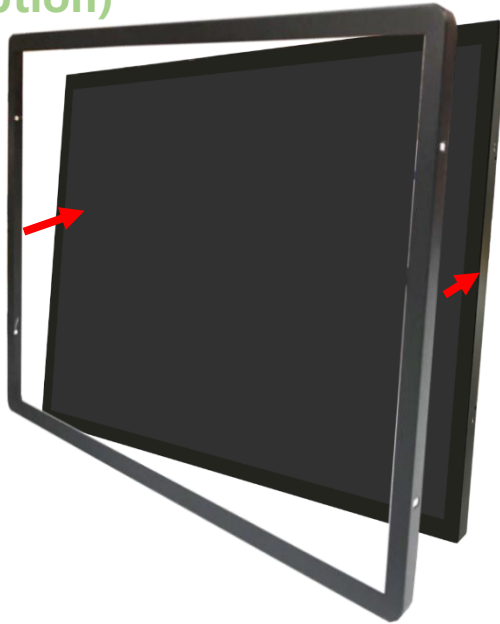

The standard **NTSP150** is true flat surface, with only 1mm metal bezel. To protect the corners of the touch screen, the **Front Cover** can be added.

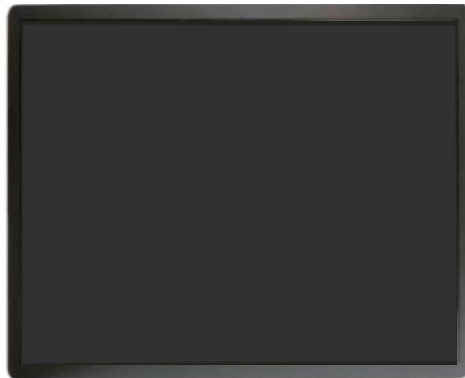

The watertight gasket can be added between the **Front Cover** and **NTSP150**. It complies **IP65** on front.

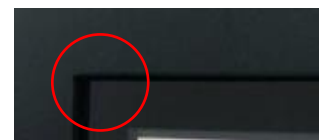
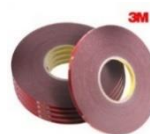
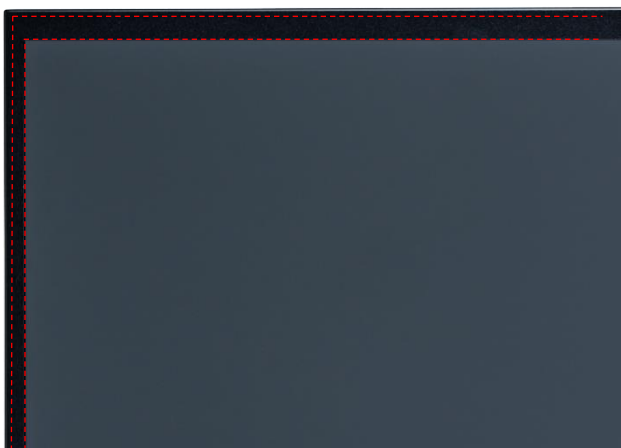

## Open-frame Brackets (Option)

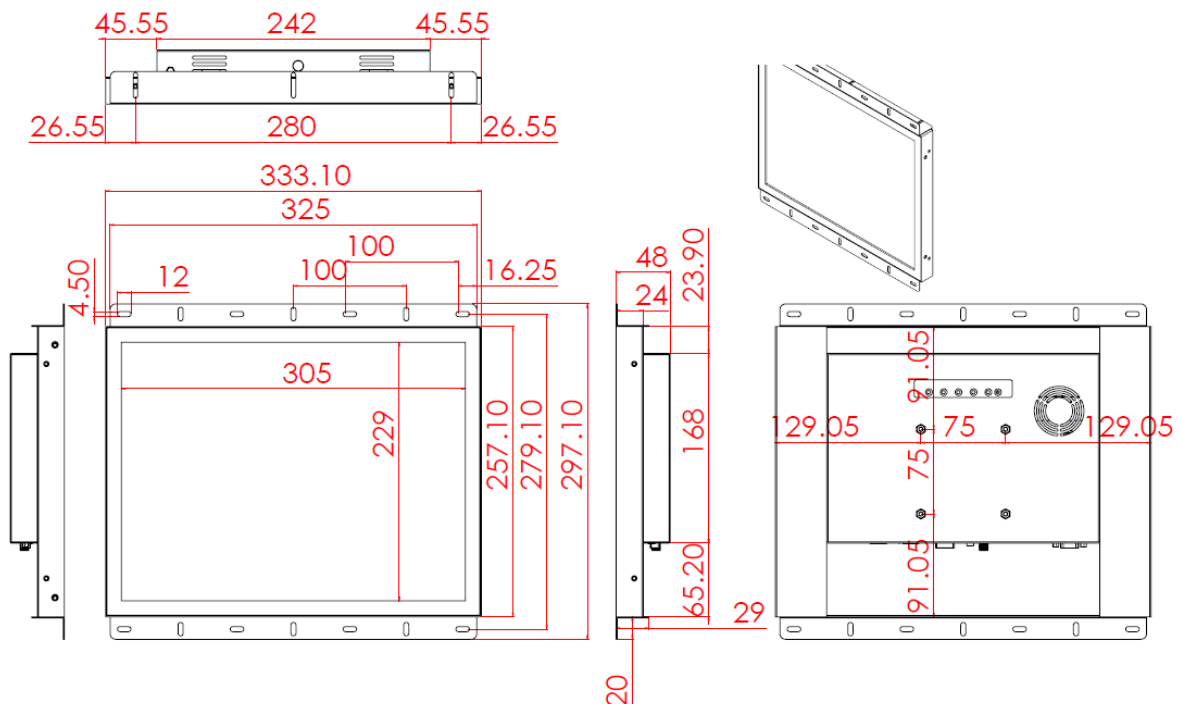
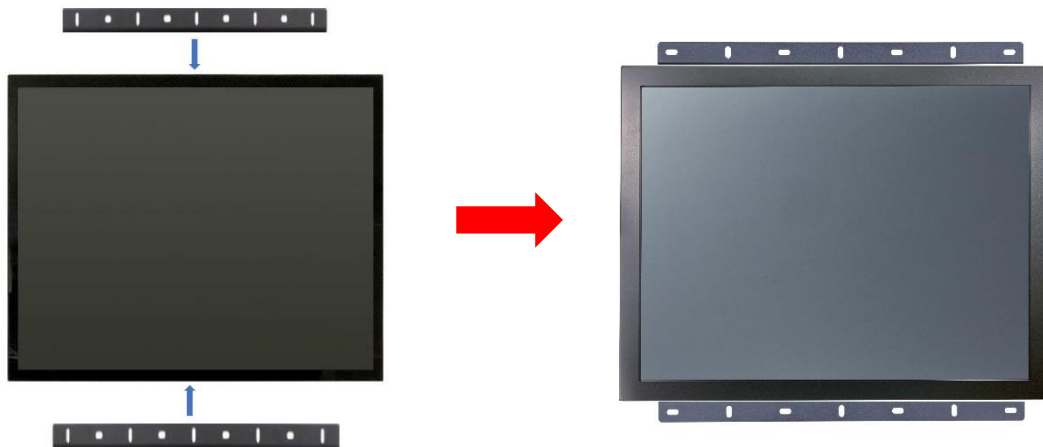

Panel Mount Kits (Option)

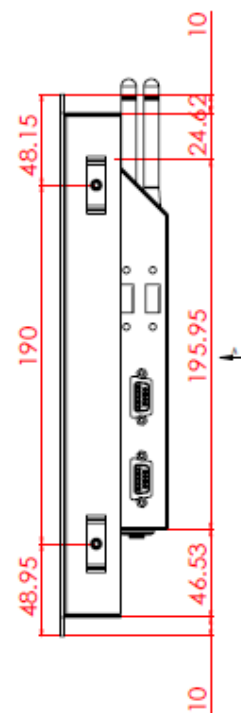
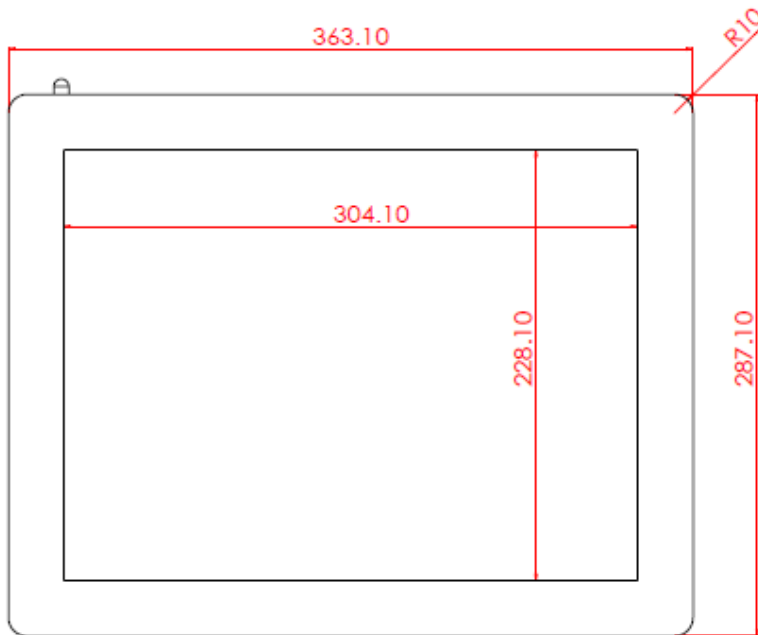
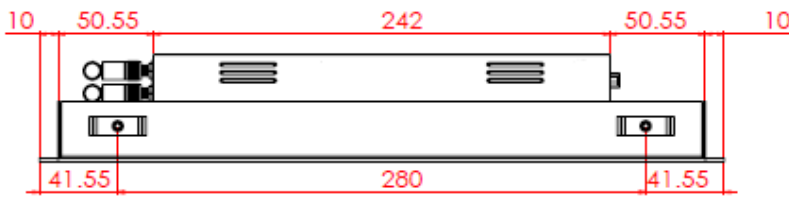

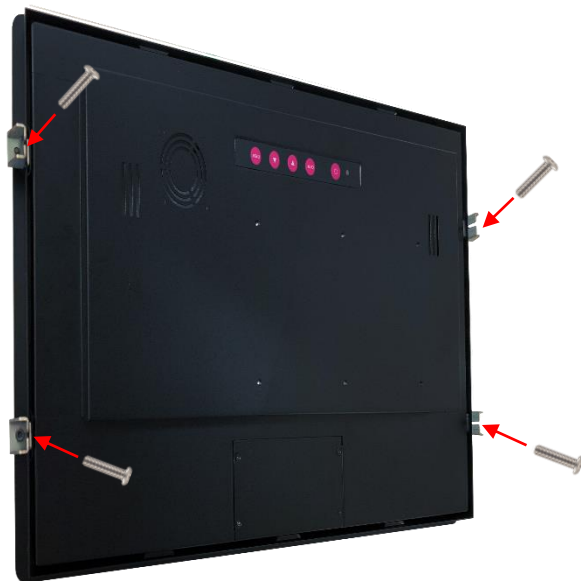
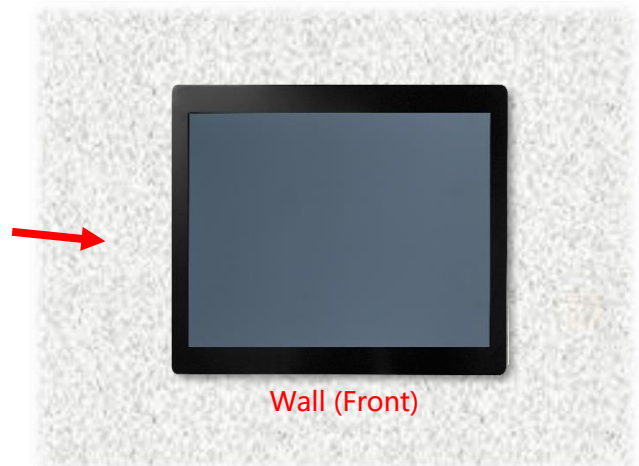
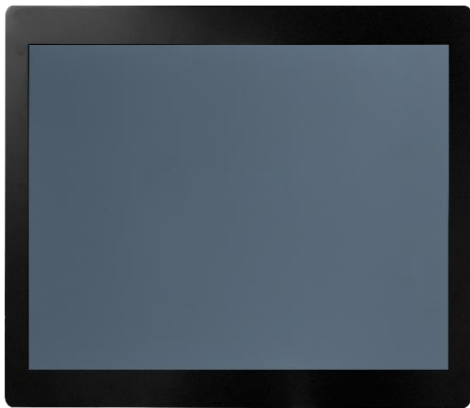
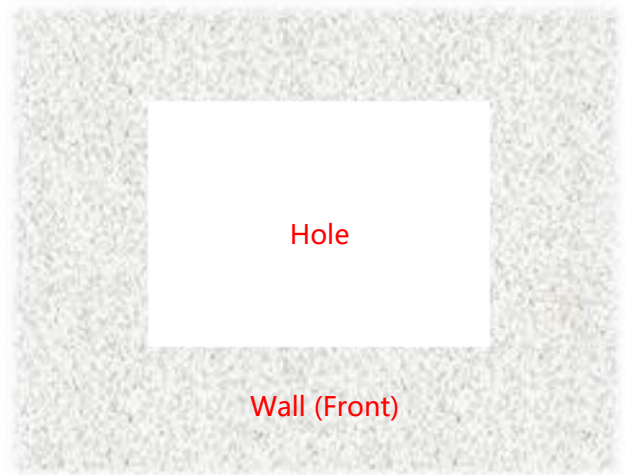
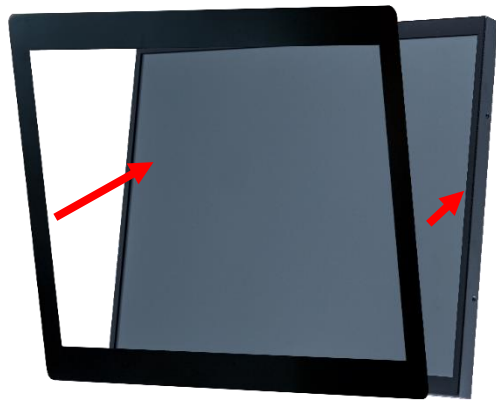

### Desktop Stand (Option)

Item	L Stand	Part No.	DST-0B004/DST-1B004
Mounting Pattern	100x100 / 75x75 mm	Dimension (WxHxD)	194x194x222 mm
Material	SECC	Net Weight	1.4 KG
Tilt (Hinge)	105°	Support Max. Weight	15 KG



Item	B Stand	Part No.	DST-0B002/DST-1B002
Mounting Pattern	100x100 / 75x75 mm	Dimension (WxHxD)	203x275x227 mm
Material	Steel/Plastic/Aluminum	Net Weight	1.8 KG
Tilt (Hinge)	-2° ~ +180°	Support Max. Weight	15 KG



## Wall Mount Bracket (Option)

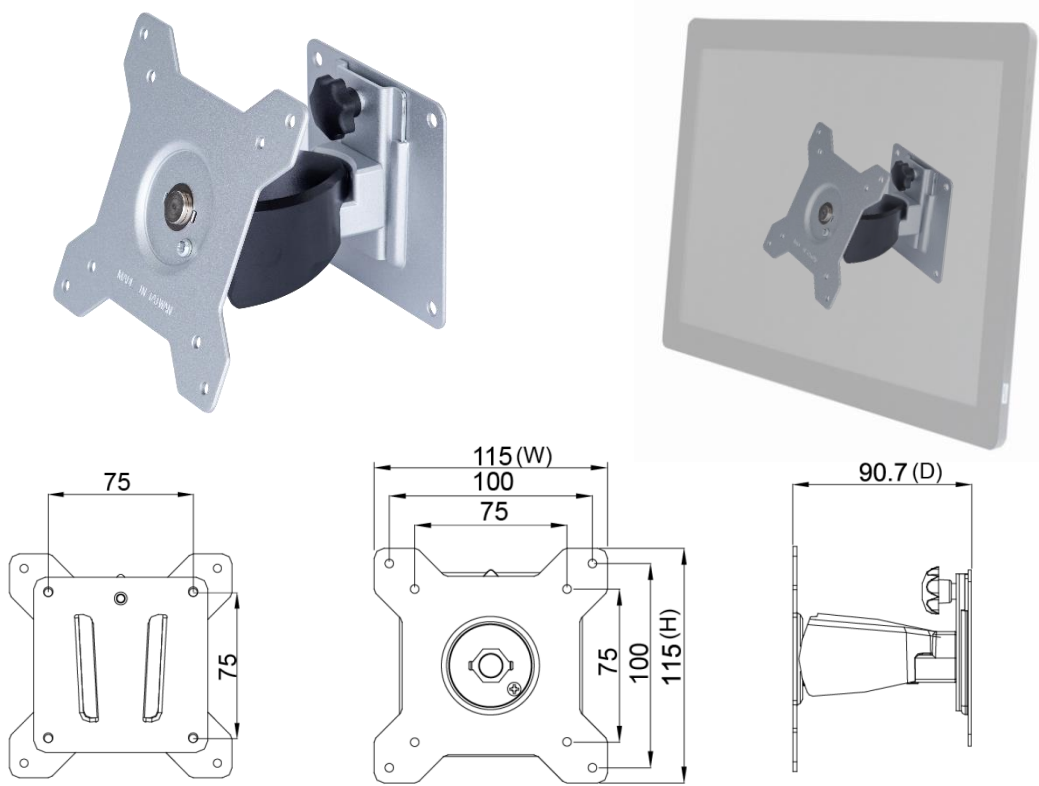

## Packing Information

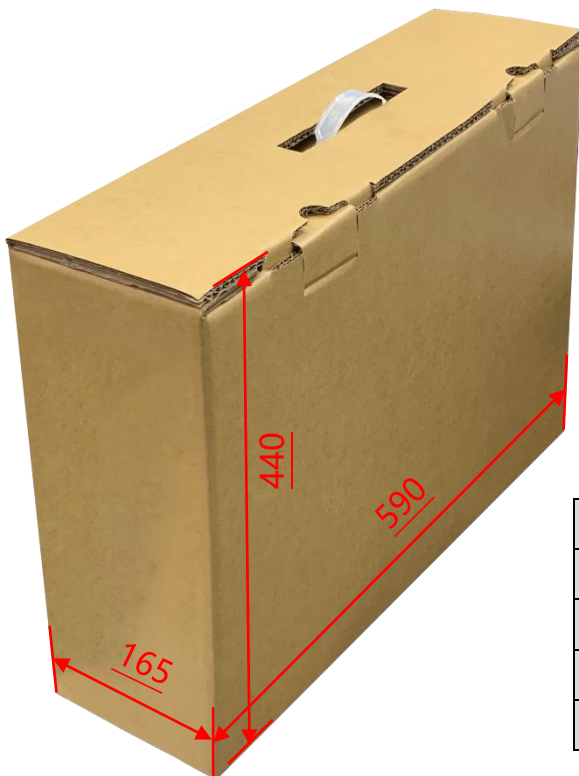

Unit Carton Size	<b>590x165x440 mm</b>
Unit N. Weight	<b>≤2.9 KG</b>
Unit G. Weight	<b>≤4.8 KG</b>
Units per Pallet	<b>36 units</b>
Pallet Size	<b>120x100x147 CM</b>

## Physical Specifications

Dimension (Max)	<b>333x257x48(±2)mm</b>	Net Weight	<b>≤2.9 KG</b>
VESA Mounting	<b>75x75 mm</b>	Gross Weight	<b>≤4.8 KG</b>

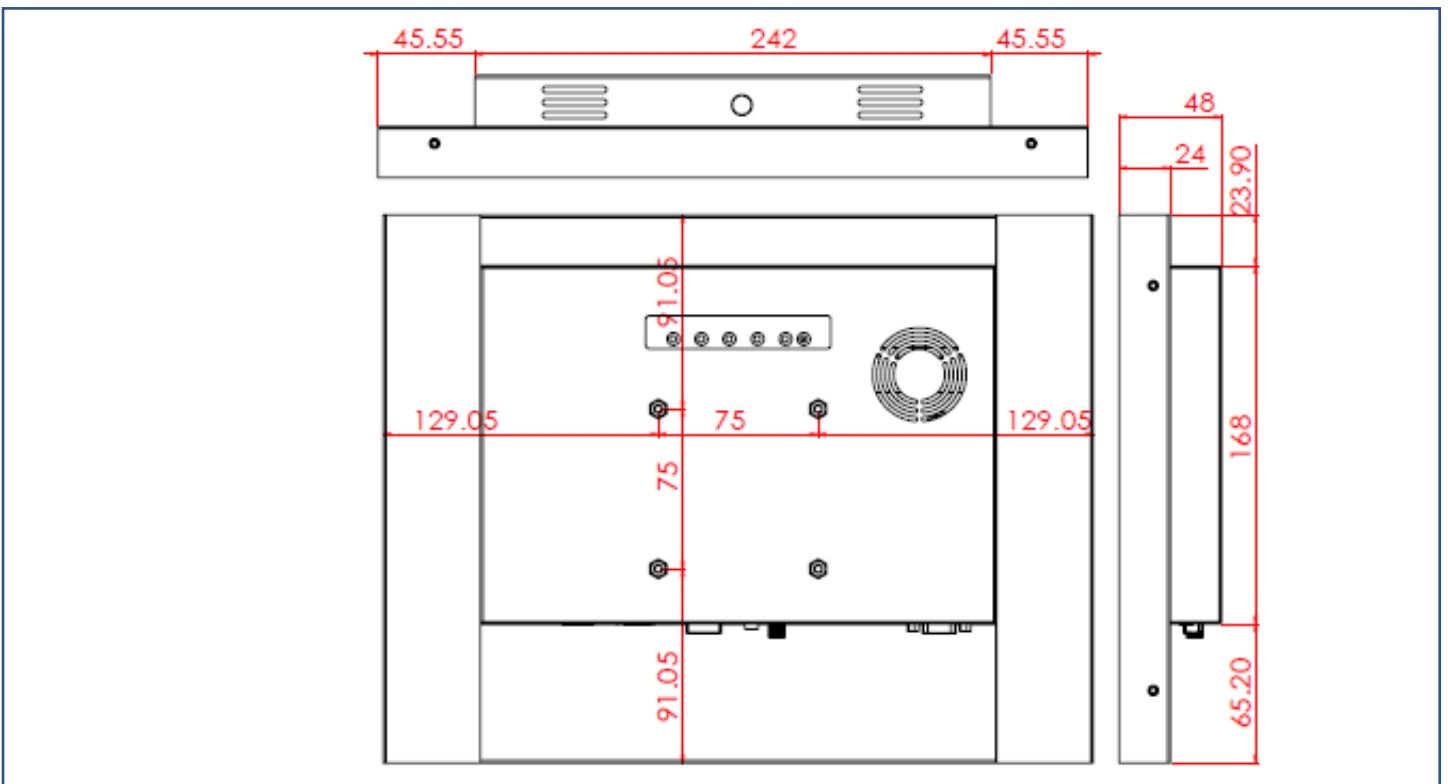
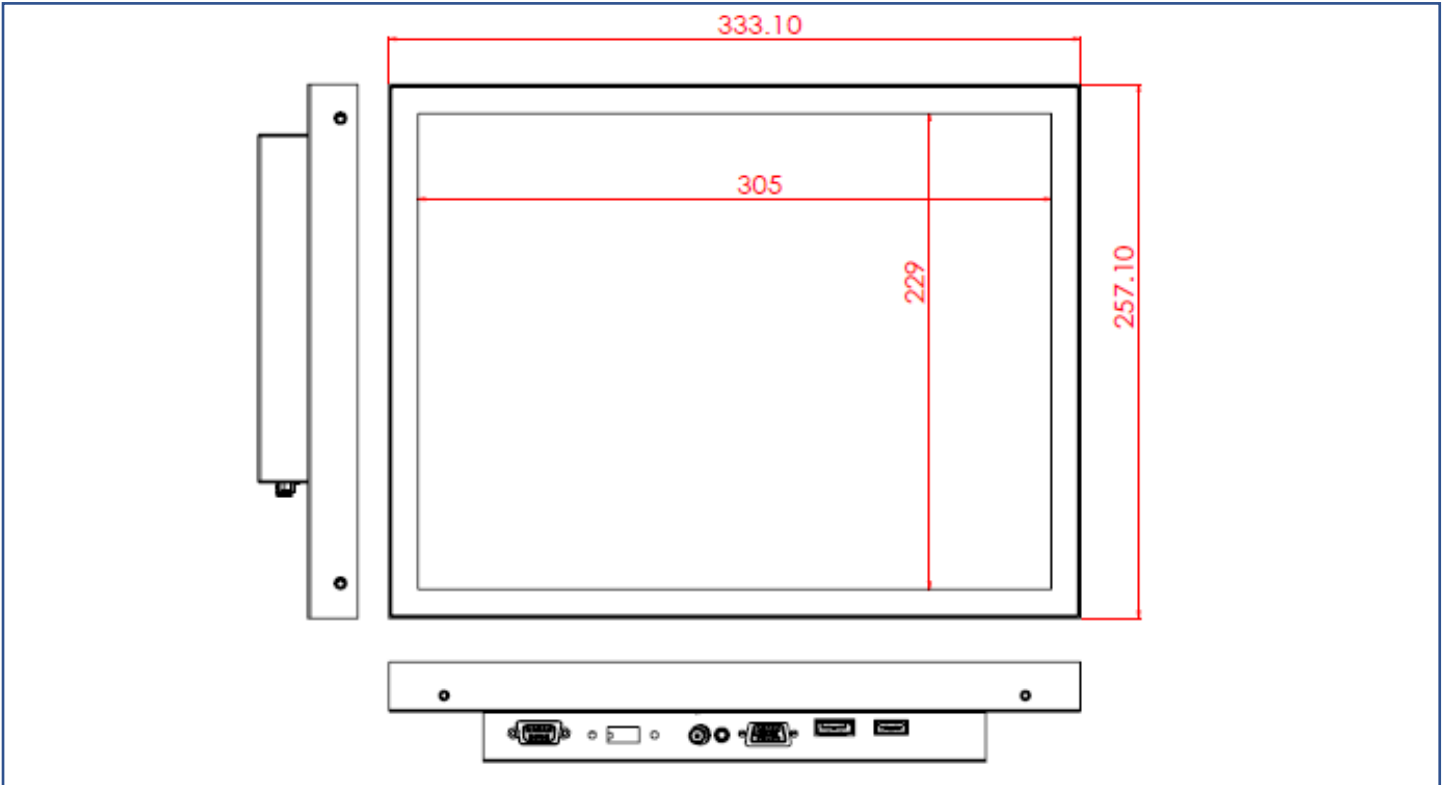

## Cosmetic Inspection Standard

Display Area Allowance			
Defect description	Defective Specifications	Allowance	Remarks
Dot Defect (including dark dot, particles, bubbles, pits, dust, foreign matter)	$D \leq 0.2\text{mm}$	Ignored	D=Diameter
	$0.2 < D \leq 0.7\text{mm}$	$N \leq 5$	N=Quantity
	$0.7 < D \leq 1\text{mm}$	$N \leq 3$	
	$D > 1\text{mm}$	$N \leq 0$	
Linear Defect (including scratches, fluff, particles)	$W \leq 0.15\text{mm}$	Ignored	W=Width
	$0.15 < W \leq 0.5\text{mm}, L \leq 15\text{mm}$	$N \leq 2$	L=Length
	$W > 0.5\text{mm}$ or $L > 15\text{mm}$	NG	

\* Visual inspection distance: 60cm, 90 degree (same for front/side/back)

Front Appearance Allowance (Including Coating)			
Defect description	Defective Specifications	Allowance	Remarks
Dot Defect (including particles, bubbles, pits...etc.)	$D \leq 0.7\text{mm}$	Ignored	D=Diameter
	$0.7 < D \leq 1.5\text{mm}$	$N \leq 3$	N=Quantity
	$D > 1.5\text{mm}$	$N \leq 0$	
Linear Defect (including scratches, fluff, particles)	$W \leq 0.2\text{mm}, L \leq 15\text{mm}$	Ignored	W=Width, L=Length
	$0.2 < W \leq 0.7\text{mm}, L \leq 15\text{mm}$	$N \leq 1$	
	$W > 0.7\text{mm}$ or $L > 15\text{mm}$	NG	

Side / Back Appearance Allowance (Including Coating)			
Defect description	Defective Specifications	Allowance	Remarks
Dot Defect (including particles, bubbles, pits...etc.)	$D \leq 1.5\text{mm}$	Ignored	D=Diameter
	$1.5 < D \leq 3\text{mm}$	$N \leq 8$	N=Quantity
	$D > 3\text{mm}$	$N \leq 2$	
Linear Defect (including scratches, fluff, particles)	$W \leq 0.8\text{mm}, L \leq 15\text{mm}$	Ignored	W=Width, L=Length
	$0.8 < W \leq 1.5\text{mm}, L \leq 15\text{mm}$	$N \leq 5$	
	$W > 1.5\text{mm}$ or $L > 15\text{mm}$	NG	

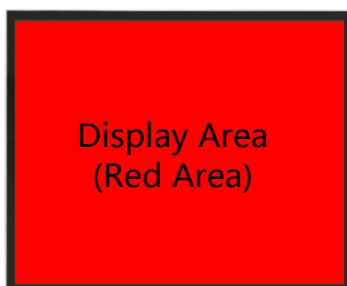

Display Area  
(Red Area)



Front Appearance (Red Area)



Back Appearance